

# INCLINATOR<sup>®</sup> LX HOME ELEVATOR

*The luxury car that never leaves your home*



# *Beautifully designed. Masterfully engineered.*

Inclinator elevators are individually designed, hand-crafted and use the most advanced home elevator technology. We're still family-owned and focused on delivering the highest-quality and most reliable home elevator. We believe that's why there are more Inclinator elevators in homes across America than any other brand.

In fact, the LX has more technology than any other home elevator. We have so much confidence that we gave it an industry-leading warranty: 3 years on parts and components, and 5 years on the motor.

## **LX features:**

- The most customizable home elevator
- Gearless traction motor
- Super smooth ride
- Virtually noiseless operation
- Unique patent-pending emergency lowering system
- Machine roomless
- Install in new home or add to existing home

## **Setting a standard for environmentally-friendly home elevators:**

- Machine roomless – less sq. ft. and construction materials
- Slower motor speed – reduces energy consumption
- Gearless motor – longer life span than geared motors
- No hydraulic or gear oils – no risk of soil contamination

# *Enjoy the ride.*



Car interior shown with custom finish.

Inclinor elevator can match any design and finish of the home's décor.





### **A proud heritage of innovation and excellence.**

In 1923, Harrisburg, PA inventor C.C. Crispen created a way for his ailing friend to travel from floor to floor. His idea was to build a seat that would climb stairs. He called it the Inclinator. Five years later, he built his first elevator as an alternative for homes with winding stairs. He called it the Elevette. Through the years, vertical wheelchair lifts and dumbwaiters were added, while the Elevette® continued to be refined. In 2007, Inclinator introduced the LX, the industry's most advanced home elevator.

### **More custom features than any other elevator**

- 4 car styles with custom options
- Custom sizes up to 15 sq. ft.
- Door openings on 1, 2 or 3 sides
- Travel up to 50 ft.
- Can accommodate up to 6 landings
- Nearly all wood species available
- Stained or painted in factory or on-site



# Car Styles



## LX 500

Aluminum frame with acrylic panels

*Enclosed shaft required*



## LX 400

Solid wood with hardwood veneer raised or recessed panels

*Panel configurations include 2-over-2 or 1-over-1*



## LX 300

Smooth hardwood panels with crown, chair, baseboard and picture molding



## LX 200

Smooth hardwood veneer panels with flush corners

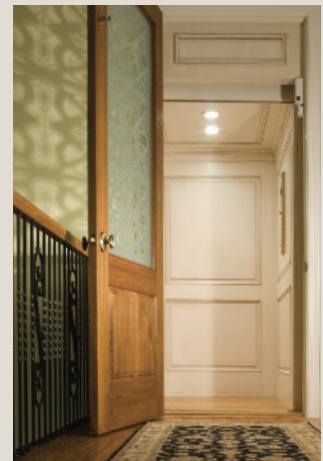

# Car Finishes & Accessories

## Walls

Just about any wood species available can be used for LX construction. The majority of cars are made using hardwoods and veneers in one of the standard or premium woods shown. Available in semi-gloss coat or satin finish. Most cars are finished in the factory, but they can remain unfinished for on-site, custom finishing.

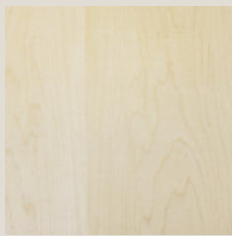

Maple (standard)

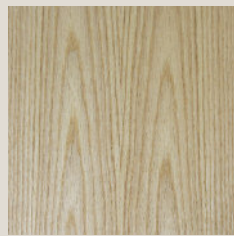

Light Oak (standard)

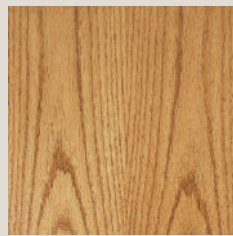

Medium Oak (premium)

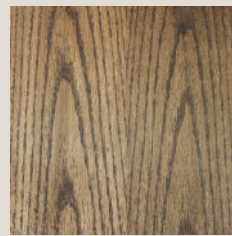

Dark Oak (premium)

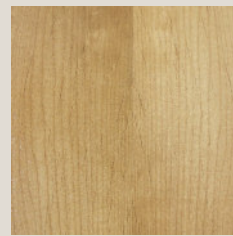

Clear Alder (premium)

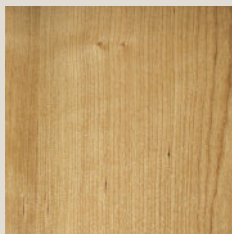

Cherry (premium)

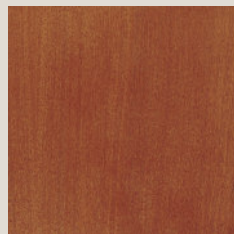

Stained Cherry (premium)

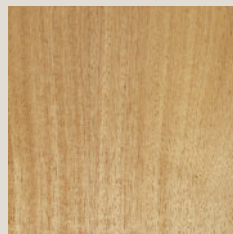

Mahogany (premium)

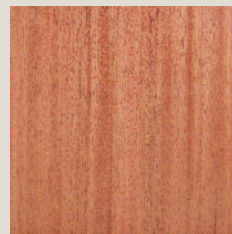

Stained Mahogany (premium)

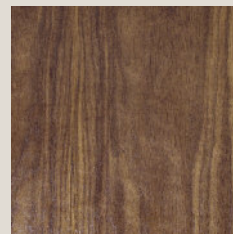

Walnut (premium)

## Handrails

Standard flat wood handrails are finished to match walls. Optional round metal handrails are available in various finishes. Custom designs and finishes are always available.



Bronze round handrail with natural cherry wood.



Wood (to match car finish)



Stainless Steel



Brass



Bronze



Oil-Rubbed Bronze

Actual colors may vary slightly from printed samples.



## Floor

Inclinor elevators include hardwood laminate finishes for floor. Elevators can also be ordered with custom flooring or with unfinished oak for custom on-site finishing.



Maple (laminate)



Natural Oak (laminate)



Cherry (laminate)



Walnut (laminate)



Unfinished Oak

## Ceiling

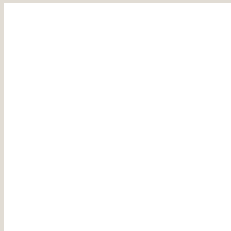

White (laminate)

Inclinor elevators include white laminated ceiling panel standard. All wall veneers (see page 6) are available – as an option – for matching ceiling and walls.

## Lights & Trims

Every elevator comes with one ceiling light. Multiple lights and different fixtures are optional.

### STANDARD: 6" Down Light with Glass Lens



Polished Stainless Steel Ring

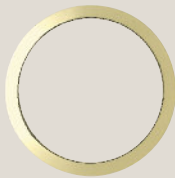

Brass Ring



Bronze Ring



Oil-Rubbed Bronze Ring



Duranotic Ring



White Ring

### OPTIONAL: Down Lights Flush with Dome



Surface Mounted Light  
2" x 9-1/2" x 9-1/2"



6" Down Light  
with black cone baffle  
& white trim ring



4" Down Light  
with white cone baffle

Actual colors may vary slightly from printed samples.

# Car Finishes & Accessories

## Gates

Inclinators elevators come with a collapsible gate. Accordion fold gate is an option. Automatic gate operators are also an option.

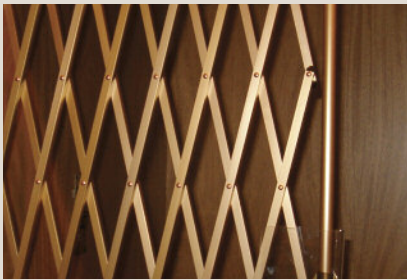

Collapsible Gate

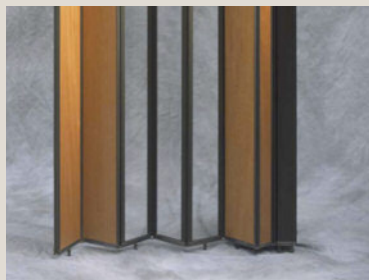

Accordion Fold Gate



Extruded gate track matches metal finish on either gate option.

### Standard Metal Finishes



Silver

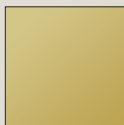

Brass

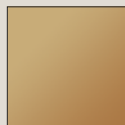

Bronze

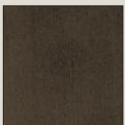

Oil-Rubbed Bronze

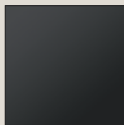

Duranotic

### Standard Hardwood Finishes



Maple/Birch

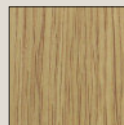

Oak

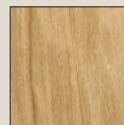

Cherry

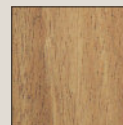

Mahogany

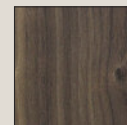

Walnut

### Standard Vinyl Laminates

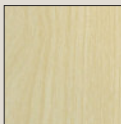

Maple/Birch

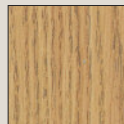

Light Oak

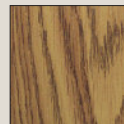

Dark Oak

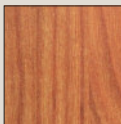

Cherry

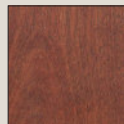

Mahogany

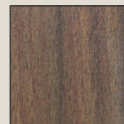

Walnut



White

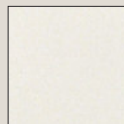

Antique White

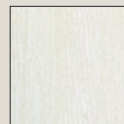

Chalk



Beige

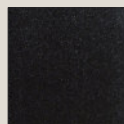

Black

### Acrylic Vision Panels



Clear

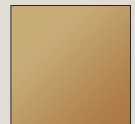

Bronze (tint)

### Accordion Fold Gate Frames



Nickel



Brass (premium)

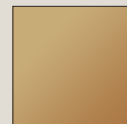

Bronze



White (premium)

Actual colors may vary slightly from printed samples.

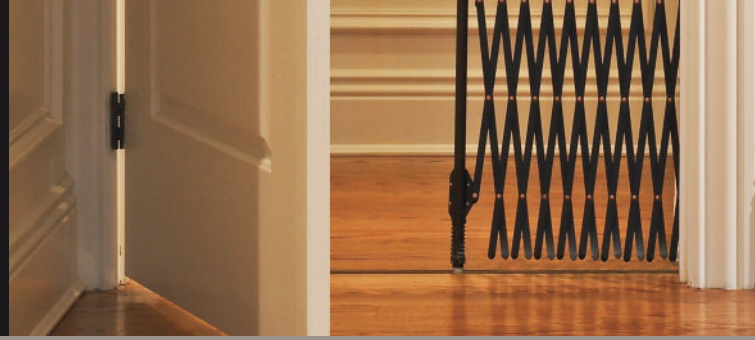

## Car Operating Stations

Each elevator includes a Car Operating Panel. The faceplate will vary depending on finish selected and the number of elevator landings. A Remote Call Station is placed on each landing by the elevator door.



Car Operating Panel – configuration determined by the elevator's use requirements.



Remote Call Station (at each landing) available in matching finishes to Car Operating Panel – for interior use only.

### Standard Finishes



Brushed Stainless

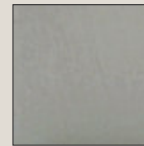

Polished Stainless

### Optional Finishes



Brushed Brass

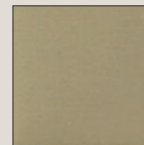

Polished Brass



Bronze

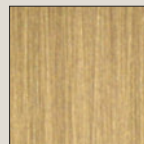

Antique Bronze

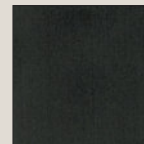

Duranotic

Regardless of metallic finish selected, top & bottom end caps and buttons are brushed stainless.

Actual colors may vary slightly from printed samples.

# Elevator Details

## Typical Car Configurations

Elevator car can have door openings on 1, 2 or 3 sides. As you can see, Inclinator offers more configurations than any other manufacturer.



Some configurations are not suitable for wheelchair use. Consult Inclinator (manufacturer) for recommendations.

## Machine Roomless Car and Shaft Sizes

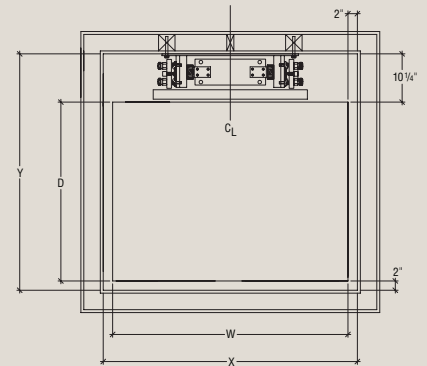

Notes:

- Typical 1" running clearance from finished hoistway to edge of car at all door openings
- 3" running clearance – typically opposite the railway – required for traveling cable
- Minimum overhead needed for 7' tall car elevator is 8'-6"

# Drive System

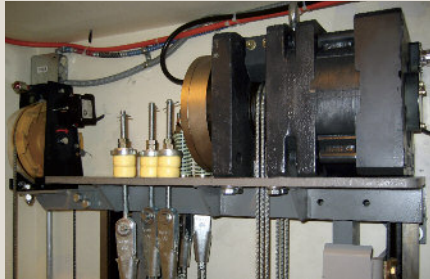

## Gearless Traction Motor

- Super smooth ride
- Virtually noiseless operation
- Contains no hydraulic or gear oil (no smell or potential spills)
- 950 lb. capacity (highest allowable capacity)
- Cable traction for raising/lowering
- Patent-pending emergency lowering system
- Type "A" instantaneous safeties
- Overspeed governor



## Microprocessor-Based Controller

- Upgraded electrical technology
- Self-diagnostic
- Easier to maintain and service
- Programmable controller allows customization of many features

Note: Indoor use only. Must be in temperature-controlled environment.



## Double-Rail Chassis

- Precision engineering
- Very stable
- Holds motor; eliminates machine room

# Safety

## Standard Safety Features



## Gate Safety Switch

This requires the gate to remain closed during the car's movement.

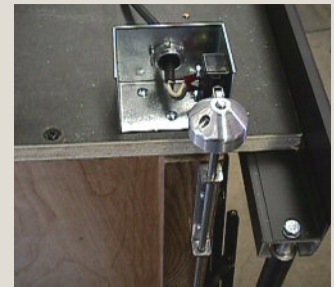

## Car Floating Gate Switch

This stops the car when an object extends through the gate and forces it up or down.

Meets or exceeds the requirements of ASME A17.7, ASME A17.1-2007 and CSA B44-07 safety codes for elevators and escalators.





*You can be confident in choosing an Inclinotor product*



### HOME ELEVATORS

- The industry's most customizable home elevator
- Two lines: LX and ELEVETTE®



### WHEELCHAIR LIFTS

- Indoor and outdoor use
- Two lines: SpectraLift® (fiberglass) and VL (steel)



### DUMBWAITERS

- Custom sizes and features
- Two lines: Dumbwaiter (commercial use) and Homewaiter® (residential use)

Consult your local building authorities for specific regulations on these products before purchasing. Specifications, material finishes and product options are subject to change without notice.



**INCLINATOR**  
COMPANY OF AMERICA

601 Gibson Boulevard, Harrisburg, PA 17104

Phone: 717-939-8420

**Toll-Free: 800-343-9007**

**www.inclinotor.com**

isales@inclinotor.com

©2011, Inclinotor Company of America  
PO Box 1557, Harrisburg, PA 17105-1557  
Printed in USA, All Rights Reserved

85305761 - 0611